

IGLOO Refrigeration Ltd

9379 TRANSCANADIENNE - VOIE DE SERVICE NORD MONTREAL QUEBEC H4S 1V3 CANADA
 TEL: 514.344.5555 TOLL FREE: 1.866.804.4566 FAX: 514.344.2861

MULTI PURPOSE, SLIM LINE, LOW GLASS (SELF-SERVE), REFRIGERATED DISPLAY CASE

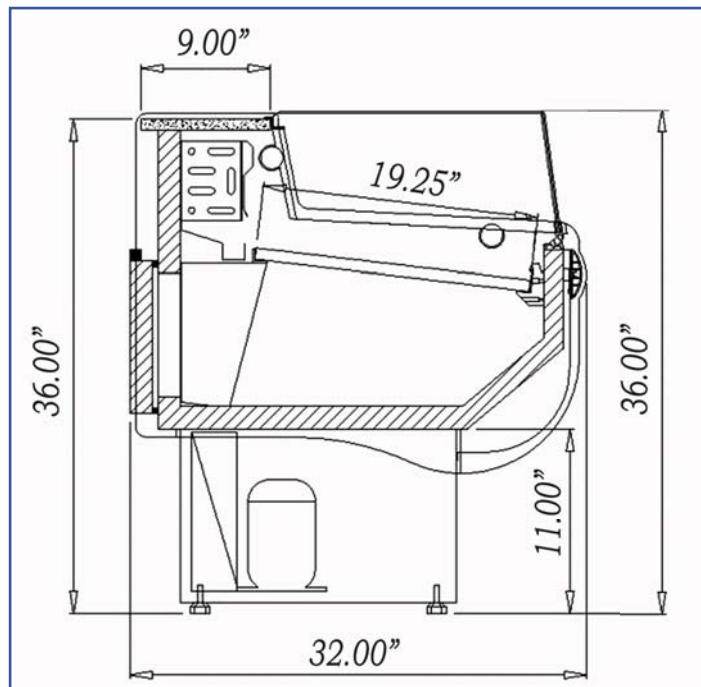

STANDARD:

- Front glass defogging system
- Stainless steel flat plates or steps, white wire shelves
- Refrigerated under shelves storage
- Top lighting system
- Digital temperature display
- Self contained
- Gravity cooling
- Temperature range: 0 °C and up
- Automatic defrost cycle
- Automatic condensation disposal
- Environment friendly R 134 a, R404A, R507A

OPTIONAL:

- Stainless steel finish
- Variety of finished colours
- Remote compressor

MODEL	LENGTH	DEPTH	HEIGHT	VOLTAGE	WEIGHT
	In./cm	In./cm	In./cm		Lbs/Kg
MLM 3	41 / 105	32 / 83	35 / 89	115V 60Hz 8A	233 / 106
MLM 4	51 / 130	32 / 83	35 / 89	115V 60Hz 8A	270 / 123
MLM 5	59 / 150	32 / 83	35 / 89	115V 60Hz 8A	305 / 138
MLM 6	67 / 170	32 / 83	35 / 89	115V 60Hz 8A	334 / 151
MLM 7	80 / 200	32 / 83	35 / 89	115V 60Hz 8A	377 / 171
MLM 8	99 / 250	32 / 83	35 / 89	115V 60Hz 8A	427 / 194

* All equipment designed to operate in controlled environment below 75°F (+24°C) temperature and HR 55% relative humidity.

** All measurements are approximates

*** Specifications are subject to change without notice

Web: www.igloorefrigeration.com