

# IGLOO Refrigeration Ltd

9379 TRANSCANADIENNE - VOIE DE SERVICE NORD MONTREAL QUEBEC H4S 1V3 CANADA  
 TEL: 514.344.5555 TOLL FREE: 1.866.804.4566 FAX: 514.344.2861

## HOT FOOD SHOW CASE – “DELUXE” – CURVED FRONT GLASS

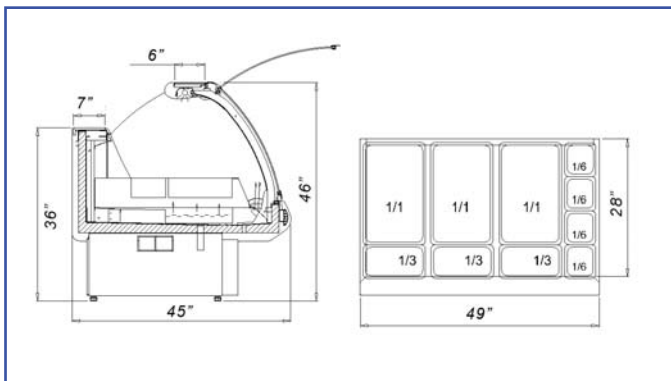

### **STANDARD:**

- Curved glass front glass
- Granite granite work counter
- Body white finish
- Illuminated display area
- Thermostat heat control

**NOTE: Panes not included in price**

MODEL	LENGTH	DEPTH	HEIGHT	VOLTAGE	WEIGHT
	In./cm	In./cm	In./cm		Lbs/Kg
<b>HFTD3</b>	41 / 104	47 / 119	48 / 123	208 / 115V 60Hz 12A	265 / 120
<b>HFTD5</b>	66 / 167	47 / 119	48 / 123	208 / 115V 60Hz 15A	375 / 170
<b>HFTD6</b>	79 / 200	47 / 119	48 / 123	208 / 115V 60Hz 20A	430 / 195
<b>HFTD8</b>	100 / 254	47 / 119	48 / 123	208 / 115V 60Hz 25A	465 / 210

\* All equipment designed to operate in controlled environment below 75°F (+24°C) temperature and HR 55% relative humidity.

\*\* All measurements are approximates

\*\*\* Specifications are subject to change without notice

**Web: [www.igloorefrigeration.com](http://www.igloorefrigeration.com)**