

# IGLOO Refrigeration Ltd

9379 TRANSCANADIENNE - VOIE DE SERVICE NORD MONTREAL QUEBEC H4S 1V3 CANADA  
 TEL: 514.344.5555 TOLL FREE: 1.866.804.4566 FAX: 514.344.2861

## COLD FOOD SHOW CASE – “DELUXE” – CURVED FRONT GLASS

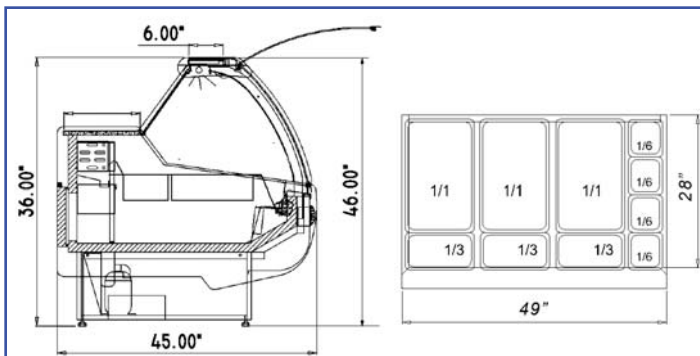

### **STANDARD:**

- Curved glass front glass
- Granite work counter
- Body white finish
- Illuminated display area
- Automatic defrost cycle
- Digital temperature display
- Automatic condensation disposal
- Environment friendly R134a or R404A

**NOTE:** Panes not included in price

MODEL	LENGTH	DEPTH	HEIGHT	VOLTAGE	WEIGHT
	In./cm	In./cm	In./cm		Lbs/Kg
<b>SSCD3</b>	41 / 104	47 / 119	48 / 123	115V 60Hz 6A	290 / 132
<b>SSCD5</b>	66 / 167	47 / 119	48 / 123	115V 60Hz 8A	400 / 181
<b>SSCD6</b>	79 / 200	47 / 119	48 / 123	115V 60Hz 8A	450 / 204
<b>SSCD8</b>	100 / 254	47 / 119	48 / 123	115V 60Hz 8A	480 / 218

\* All equipment designed to operate in controlled environment below 75°F (+24°C) temperature and HR 55% relative humidity.

\*\* All measurements are approximates

\*\*\* Specifications are subject to change without notice

**Web:** [www.igloorefrigeration.com](http://www.igloorefrigeration.com)