

IGLOO Refrigeration Ltd

9379 TRANSCANADIENNE - VOIE DE SERVICE NORD MONTREAL QUEBEC H4S 1V3 CANADA
 TEL: 514.344.5555 TOLL FREE: 1.866.804.4566 FAX: 514.344.2861

GELATO ICE-CREAM FREEZER - WOOD FINISH - SLIM LINE

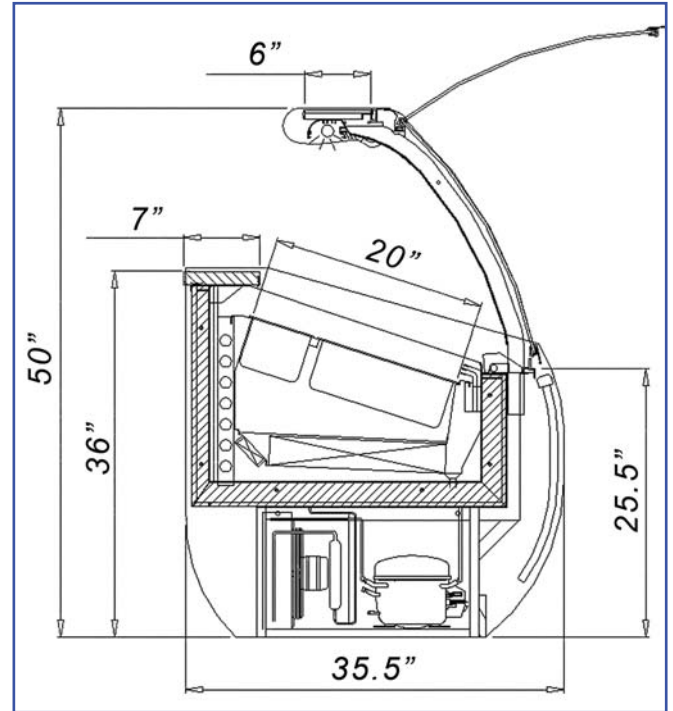

STANDARD:

- Curved glass front glass
- Wood finish base (cherry)
- Automatic defrost cycle
- Front window defogger
- Interior lighting
- Forced air cooling system
- Stainless-steel counter
- Stainless-steel containers (7 or 10) included
- Environment friendly R404A or R507

OPTIONAL:

- Remote compressor
- Gold finish trimming

MODEL	LENGTH	DEPTH	HEIGHT	VOLTAGE	WEIGHT
	In./cm	In./cm	In./cm		Lbs/Kg
ARB2-3	41 / 104	35.5 / 90	50 / 126	115V / 220V (1Phase) 60 Hz 9A	429 / 195
ARB2-4	54.5 / 138.5	35.5 / 90	50 / 126	115V / 220V (1Phase) 60 Hz 9A	540 / 245

* All equipment designed to operate in controlled environment below 75°F (+24°C) temperature and HR 55% relative humidity.

** All measurements are approximate

*** Specifications are subject to change without notice

Web: www.igloorefrigeration.com