

# IGLOO Refrigeration Ltd

9379 TRANSCANADIENNE - VOIE DE SERVICE NORD MONTREAL QUEBEC H4S 1V3 CANADA  
 TEL: 514.344.5555 TOLL FREE: 1.866.804.4566 FAX: 514.344.2861

## GELATO ICE-CREAM FREEZER

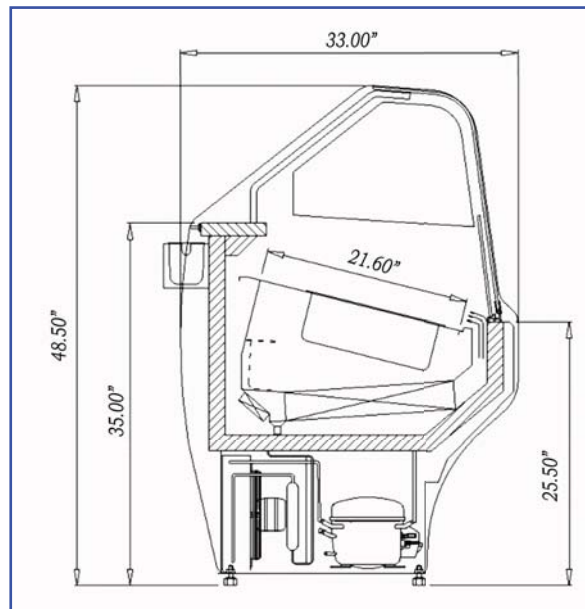

### **STANDARD:**

- Curved glass front glass
- Automatic defrost cycle
- Front window defogger
- Interior lighting
- Forced air cooling system
- Stainless-steel front and back
- Stainless-steel counter
- Curtain door cover
- Stainless-steel containers (8 or 14) included
- Environment friendly R134a or R404A

### **OPTIONAL:**

- Remote compressor
- Custom colour ABS sides

MODEL	LENGTH	DEPTH	HEIGHT	VOLTAGE	WEIGHT
	In./cm	In./cm	In./cm		Lbs/Kg
<b>EGIF 1</b>	42 / 106	33 / 84	49 / 125	115V / 208V 60 Hz 9A	260 / 118
<b>EGIF 2</b>	67 / 170	33 / 84	49 / 125	115V / 208V 60 Hz 18A	390 / 177

\* All equipment designed to operate in controlled environment below 75°F (+24°C) temperature and HR 55% relative humidity.

\*\* All measurements are approximates

\*\*\* Specifications are subject to change without notice

Web: [www.igloorefrigeration.com](http://www.igloorefrigeration.com)