

IGLOO Refrigeration Ltd

9379 TRANSCANADIENNE - VOIE DE SERVICE NORD MONTREAL QUEBEC H4S 1V3 CANADA
 TEL: 514.344.5555 TOLL FREE: 1.866.804.4566 FAX: 514.344.2861

OPEN MERCHANDISER – LOW PROFILE DAIRY, DELL, MEAT, BEVERAGE AND PRODUCE

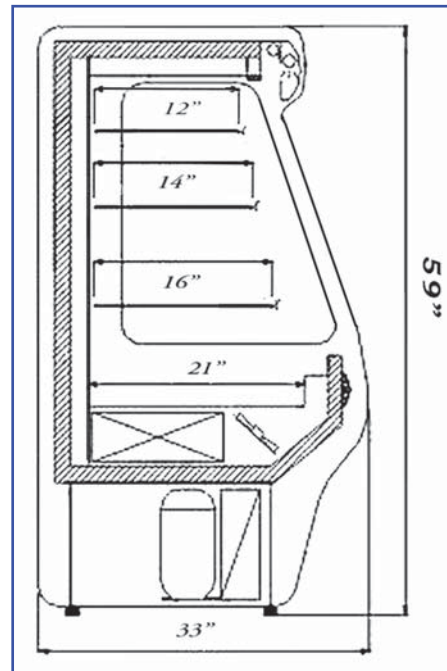

STANDARD:

- Solid ABS sides or with glass window
- Adjustable sloping shelves
- Choice of trim colour
- Body white finished inside and outside
- Electronic programmable temperature
- Digital temperature display
- Automatic condensation disposal
- Forced air cooling system with top air flow
- Self-contained case
- Night curtain

OPTIONAL:

- Remote compressor
- Variety of finished colours
- Possibility of multiplexing
- Hooks
- Painted white wire baskets for produce
- Lights on all shelves

MODEL	LENGTH	DEPTH	HEIGHT	VOLTAGE	WEIGHT
	In./cm	In./cm	In./cm		Lbs/Kg
30M3	40 / 101	33 / 83	59 / 150	115V 60 Hz 15A	260 / 120
30M4	52 / 129	33 / 83	59 / 150	115V 60 Hz 15A	310 / 140
30M5	64 / 163	33 / 83	59 / 150	115V 60 Hz 15A	350 / 160
30M6	76 / 193	33 / 83	59 / 150	115V 60 Hz 15A	420 / 190
30M8	100 / 254	33 / 83	59 / 150	115V 60 Hz 2 x 15A	750 / 340
30M10	124 / 325	33 / 83	59 / 150	115V 60 Hz 2 x 15A	860 / 390
30M12	148 / 376	33 / 83	59 / 150	115V 60 Hz 2 x 15A	970 / 440

* All equipment designed to operate in controlled environment below 75°F (+24°C) temperature and HR 55% relative humidity.

** All measurements are approximates

*** Specifications are subject to change without notice

Web: www.igloorefrigeration.com