

IGLOO Refrigeration Ltd

9379 TRANSCANADIENNE - VOIE DE SERVICE NORD MONTREAL QUEBEC H4S 1V3 CANADA
 TEL: 514.344.5555 TOLL FREE: 1.866.804.4566 FAX: 514.344.2861

OPEN MERCHANDISER – SLIM LINE
DAIRY, DELI, MEAT, BEVERAGE AND PRODUCE

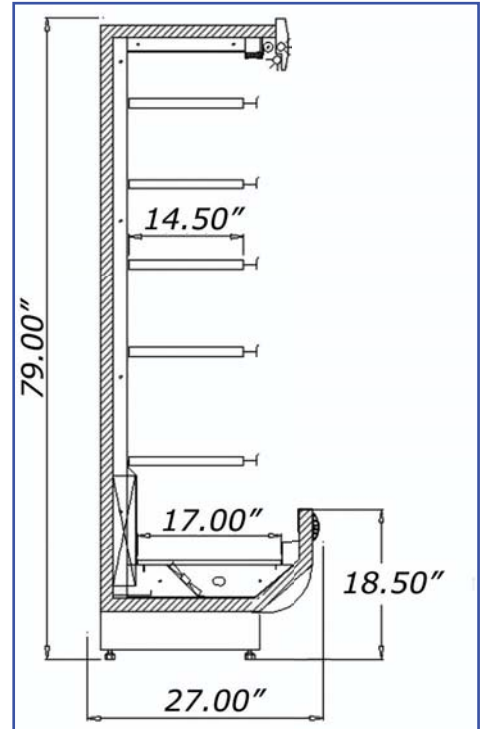

STANDARD:

- ABS sides with glass ends
- Choice of trim colour
- Body white finished inside and outside
- Electronic programmable temperature
- Digital temperature display
- Power light and compressor switch
- Automatic condensation disposal
(self contained units only)
- Forced air cooling system with top air flow
- Night curtain

OPTIONAL:

- Remote compressor
- Variety of finished colours
- Possibility of multiplexing
- Stainless-steel hooks
- Painted white wire baskets
for produce

MODEL	LENGTH	DEPTH	HEIGHT	VOLTAGE	WEIGHT
	In./cm	In./cm	In./cm		Lbs/Kg
1OM3	51 / 129	27 / 70	78 / 196	115V 60 Hz 15A	308 / 140
1OM4	64 / 163	27 / 70	78 / 196	115V 60 Hz 15A	325 / 148
1OM5	76 / 193	27 / 70	78 / 196	115V 60 Hz 15A	350 / 160
1OM6	100 / 254	27 / 70	78 / 196	115V 60Hz 15A	400 / 180
1OM8	124 / 325	27 / 70	78 / 196	115V 60 Hz 2 x 15A	660 / 300
1OM10	148 / 376	27 / 70	78 / 196	115V 60 Hz 2 x 15A	700 / 320
1OM12	148 / 376	27 / 70	78 / 196	115V 60 Hz 2 x 15A	800 / 360

*All equipment designed to operate in controlled environment below 75°F (+24°C) temperature and HR 55% relative humidity.

** All measurements are approximates

*** Specifications are subject to change without notice

Web: www.igloorefrigeration.com