

IGLOO Refrigeration Ltd

9379 TRANSCANADIENNE - VOIE DE SERVICE NORD MONTREAL QUEBEC H4S 1V3 CANADA
 TEL: 514.344.5555 TOLL FREE: 1.866.804.4566 FAX: 514.344.2861

OPEN MERCHANDISER – LOW PROFILE DAIRY, DELI, MEAT, BEVERAGE AND PRODUCE

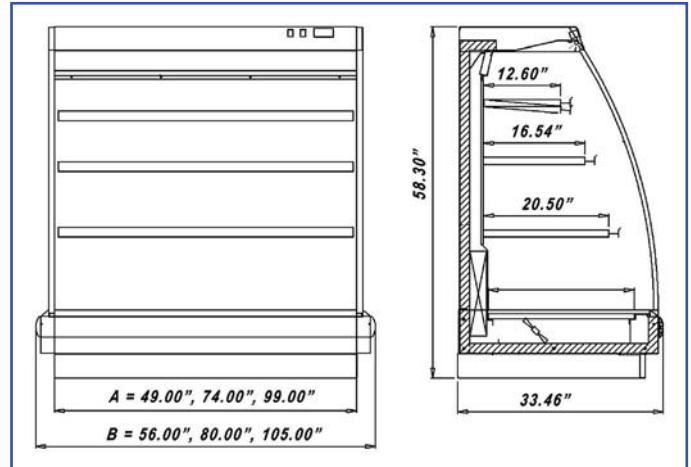

OPTIONAL:

- Possibility of multiplexing
- Hooks
- Painted white wire baskets
for produce
- Variety of finished colours

STANDARD:

- Sides with glass ends
- Adjustable sloping shelves
- Choice of trim colour
- Interior lights on all shelves
- Body – painted white inside and outside
- Electronic programmable temperature
- Digital temperature display
- Power light and compressor switch
- Forced air cooling system with top air flow
- Night curtain
- Direct connection to drain for
condensation disposal
- Expansion valve
- Case only (remote condensing unit not included)

MODEL	LENGTH	DEPTH	HEIGHT	VOLTAGE	WEIGHT
	In./cm	In./cm	In./cm		Lbs/Kg
TAB4	56 / 141	34 / 112	59 / 198	115V / 208V 60 Hz 5A	168 / 76
TAB6	80 / 204	34 / 112	59 / 198	115V / 208V 60 Hz 10A	308 / 140
TAB8	105 / 266	34 / 112	59 / 198	115V / 208V 60 Hz 10A	335 / 152

* All equipment designed to operate in controlled environment below 75°F (+24°C) temperature and HR 55% relative humidity.

** All measurements are approximate

*** Specifications are subject to change without notice

Web: www.igloorefrigeration.com