

IGLOO Refrigeration Ltd

9379 TRANSCANADIENNE - VOIE DE SERVICE NORD MONTREAL QUEBEC H4S 1V3 CANADA
 TEL: 514.344.5555 TOLL FREE: 1.866.804.4566 FAX: 514.344.2861

HOT DISPLAY – COUNTER TOP MULTI-USE CASE



STANDARD:

- Curved glass front glass
- All stainless-steel construction
- Stainless-steel pans
- Interior lighting
- Dry or wet heating
- Automatic temperature control

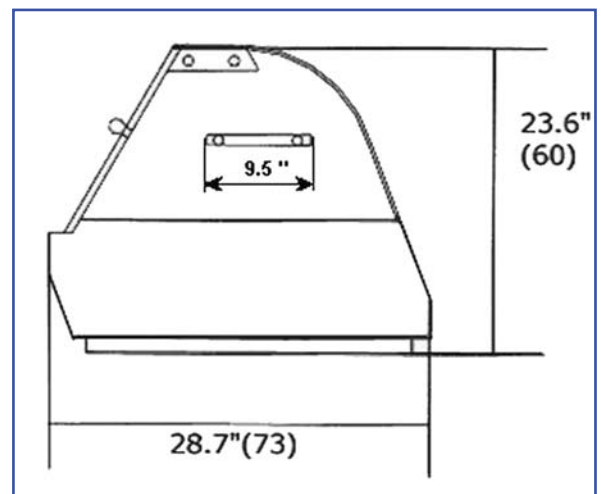

MODEL	LENGTH	DEPTH	HEIGHT	VOLTAGE	WEIGHT
	In./cm	In./cm	In./cm		Lbs/Kg
HDC2	32 / 80	29 / 73	24 / 60	115V 60Hz 10A	66 / 30
HDC3	51 / 130	29 / 73	24 / 60	115V 60Hz 12A	99 / 45

* All equipment designed to operate in controlled environment below 75°F (+24°C) temperature and HR 55% relative humidity.

** All measurements are approximates

*** Specifications are subject to change without notice

Web: www.igloorefrigeration.com