

# IGLOO Refrigeration Ltd

8355 CHEMIN MONTVIEW - MONT ROYAL MONTREAL QUÉBEC H4P 2L9 CANADA  
 TEL: 514.344.5555 TOLL FREE: 1.866.804.4566 FAX: 514.344.2861

## MULTI-USE CASE – REFRIGERATED MEAT, CHEESE, DELI, SALADS

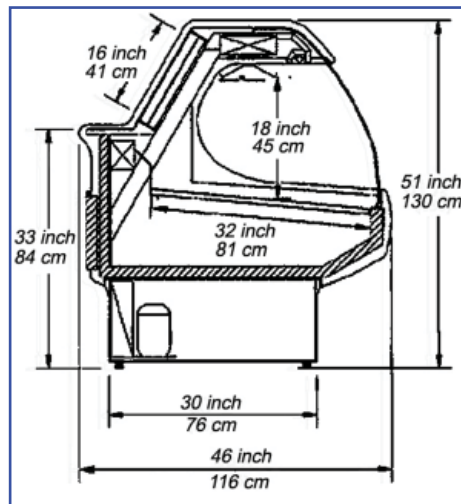

### STANDARD:

- Curved European style front glass
- Stainless-steel top counter
- Upon request: stainless-steel flat plates, steps or white wire shelves
- Interior lighting
- ABS sides
- Front bumper (grey)
- Front and base white finish
- Automatic defrost cycle
- Front glass defogging system (self-contained case only)
- Digital temperature display
- Gravity cooling system
- Automatic condensation disposal
- Environment friendly R134a
- Additional refrigerated under-shelf storage cabinet
- Self-contained case

### OPTIONAL:

- Remote compressor
- Custom colours of ABS sides
- Possibility of multiplexing
- Stainless-steel base and front
- Custom sizes available upon request.
- Custom colours of front bumper
- Mezzanine shelf with light

MODEL	LENGTH	DEPTH	HEIGHT	VOLTAGE	WEIGHT
	In./cm	In./cm	In./cm		Lbs/Kg
<b>RSC4</b>	52 / 132	45 / 115	51 / 130	115V 60Hz 8A	397 / 180
<b>RSC6</b>	76 / 193	45 / 115	51 / 130	115V 60Hz 8A	529 / 240
<b>RSC8</b>	100 / 254	45 / 115	51 / 130	115V 60Hz 15A	794 / 360
<b>RSC12</b>	148 / 376	45 / 115	51 / 130	115V 60Hz 15A	1058 / 480
<b>RSC16</b>	196 / 498	45 / 115	51 / 130	115V 60Hz 2 x 15A	1587 / 720

\* All equipment designed to operate in controlled environment below 75°F (+24°C) temperature and HR 55% relative humidity.

\*\* All measurements are approximates

\*\*\* Specifications are subject to change without notice

Web: [www.igloorefrigeration.com](http://www.igloorefrigeration.com)