

IGLOO Refrigeration Ltd

8355 CHEMIN MONTVIEW - MONT ROYAL MONTREAL QUÉBEC H4P 2L9 CANADA
 TEL: 514.344.5555 TOLL FREE: 1.866.804.4566 FAX: 514.344.2861

OPEN MERCHANDISER – HIGH PROFILE DAIRY, DELI, MEAT, BEVERAGE AND PRODUCE

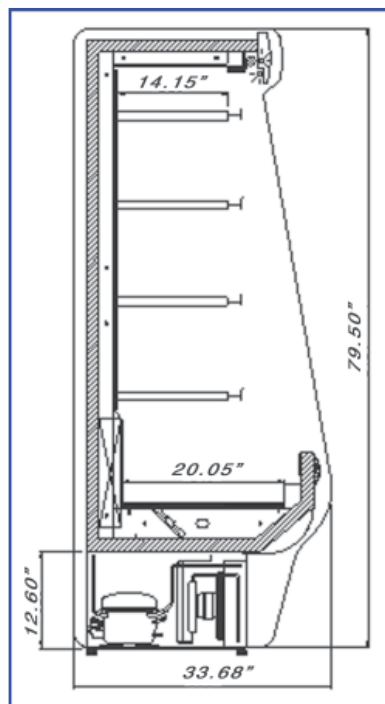

STANDARD:

- Solid ABS sides or with glass window
- Adjustable sloping shelves
- Choice of trim colour
- Body white finished inside and outside
- Electronic programmable temperature
- Digital thermometer
- Automatic condensation disposal (self contained units only)
- Forced air cooling system with top air flow
- Self-contained
- Night curtain

OPTIONAL:

- Remote compressor
- Variety of custom colours
- Lights on all shelves
- Possibility of multiplexing
- Stainless-steel hooks
- Painted white wire baskets
for produce

MODEL	LENGTH	DEPTH	HEIGHT	VOLTAGE	WEIGHT
	In./cm	In./cm	In./cm		Lbs/Kg
20M3	40 / 101	33 / 83	79 / 201	115V 60 Hz 15A	330 / 150
20M4	51 / 129	33 / 83	79 / 201	115V 60 Hz 15A	375 / 170
20M5	64 / 163	33 / 83	79 / 201	115V 60 Hz 15A	420 / 190
20M6	76 / 193	33 / 83	79 / 201	115V 60 Hz 15A	485 / 220
20M8	100 / 254	33 / 83	79 / 201	115V 60 Hz 2 x 15A	750 / 340
20M10	124 / 325	33 / 83	79 / 201	115V 60 Hz 2 x 15A	860 / 390
20M12	148 / 376	33 / 83	79 / 201	115V 60 Hz 2 x 15A	970 / 440

* All equipment designed to operate in controlled environment below 75°F (+24°C) temperature and HR 55% relative humidity.

** All measurements are approximates

*** Specifications are subject to change without notice

Web: www.igloorefrigeration.com