

IGLOO Refrigeration Ltd

8355 CHEMIN MONTVIEW - MONT ROYAL MONTREAL QUÉBEC H4P 2L9 CANADA
 TEL: 514.344.5555 TOLL FREE: 1.866.804.4566 FAX: 514.344.2861

REFRIGERATED DISPLAY – COUNTER TOP MULTI-USE CASE SALADS, SANDWICHES, SUSHI, AND MORE



STANDARD:

- Curved European style front glass
- All stainless-steel construction
- Stainless-steel pans
- Interior lighting
- Automatic defrost cycle
- Electronic programmable temperature
- Digital temperature display
- Gravity cooling system
- Automatic condensation disposal
- Environment friendly R134a

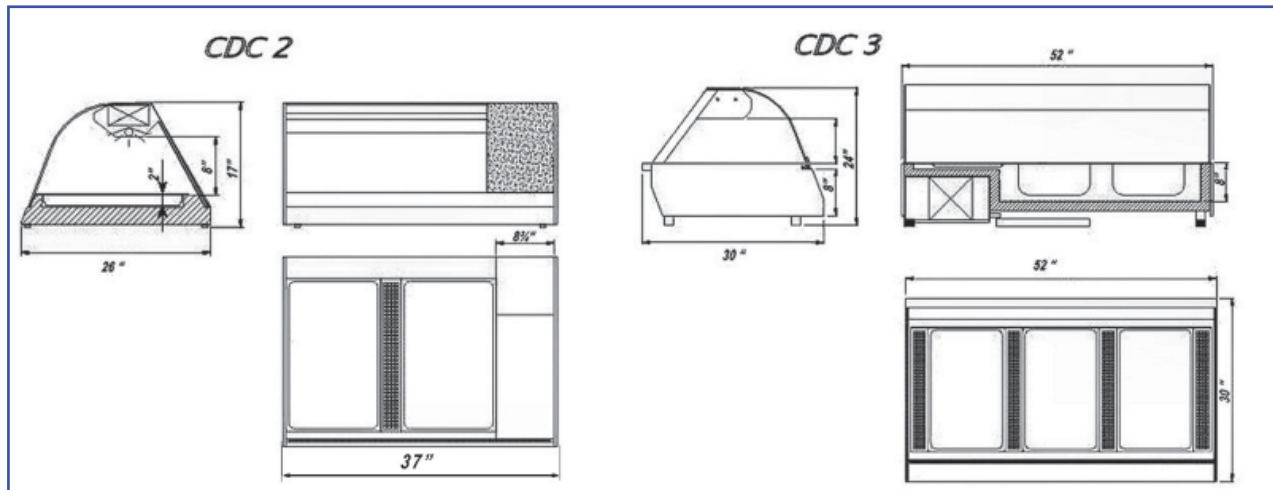

MODEL	LENGTH	DEPTH	HEIGHT	VOLTAGE	WEIGHT
	In./cm	In./cm	In./cm		Lbs/Kg
CDC 2	37 / 94	26 / 66	17 / 43	115V 60Hz 10A	66 / 30
CDC 3	52 / 132	30 / 77	24 / 60	115V 60Hz 12A	99 / 45

* All equipment designed to operate in controlled environment below 75°F (+24°C) temperature and HR 55% relative humidity.

** All measurements are approximate

*** Specifications are subject to change without notice

Web: www.igloorefrigeration.com