

# IGLOO Refrigeration Ltd

59 ALNESS STREET UNIT 3 TORONTO ONTARIO CANADA M3J 2H2  
 TEL: 416.663.3051 TOLL FREE: 1.888.408.8819 FAX: 416.663.5793

## HOT FOOD TABLES – “DELUXE” – CURVED FRONT GLASS

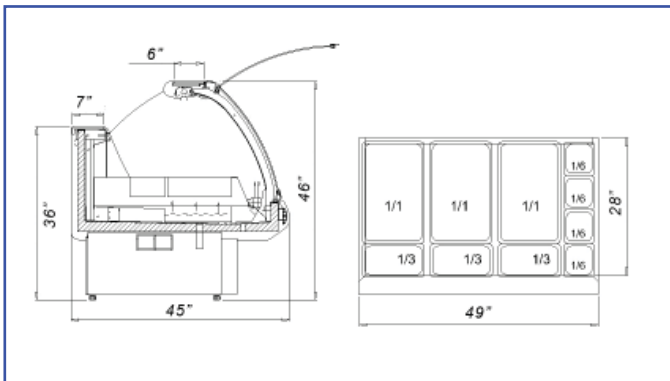

### STANDARD:

- Curved glass front glass
- Stainless-steel work counter
- Body white finish
- Lighted display area
- Low water level alarm system
- Thermostat heat control
- Additional insulated bottom storage

MODEL	LENGTH	DEPTH	HEIGHT	VOLTAGE	WEIGHT
	In./cm	In./cm	In./cm		Lbs/Kg
HFTD4	49 / 125	45 / 114	45 / 115	208 / 115V 60Hz 13A	300 / 136
HFTD8	98 / 250	45 / 114	45 / 115	208 / 115V 60Hz 25A	580 / 263

\* All equipment designed to operate in controlled environment below 75°F (+24°C) temperature and HR 55% relative humidity.

\*\* All measurements are approximates

\*\*\* Specifications are subject to change without notice

Web: [www.igloorefrigeration.com](http://www.igloorefrigeration.com)