

IGLOO Refrigeration Ltd

370 NORFINCH DRIVE TORONTO ONTARIO CANADA M3N 1Y4
 TEL: 416.663.3051 TOLL FREE: 1.888.408.8819 FAX: 416.663.5793

REFRIGERATED MULTI PURPOSE DISPLAY CASE MEAT, CHEESE, FISH, DELI AND SUSHI

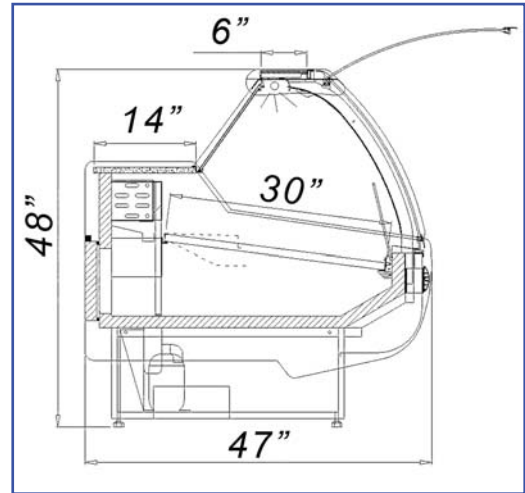

STANDARD:

- Curved glass front glass
- Granite work counter
- Interior lighting
- Additional refrigerated under-shelf storage cabinet
- ABS sides - (off-white)
- Painted white front and base
- Front bumper (grey)
- Digital temperature display
- Gravity cooling system
- Automatic defrost cycle
- Automatic condensation disposal
- Front glass defogging system
- Environment friendly R134a or R404A

OPTIONAL:

- Remote compressor
- Corner units available
- All stainless steel base and front
- Custom colours of front bumper
- Possibility of multiplexing
- Self-served units upon request
- Custom colours available

MODEL	LENGTH	DEPTH	HEIGHT	VOLTAGE	WEIGHT
	In./cm	In./cm	In./cm		Lbs/Kg
SAN3	41 / 104	47 / 119	48 / 123	115V 60Hz 6A	290 / 132
SAN5	66 / 167	47 / 119	48 / 123	115V 60Hz 8A	400 / 181
SAN6	79 / 200	47 / 119	48 / 123	115V 60Hz 8A	450 / 204
SAN8	100 / 254	47 / 119	48 / 123	115V 60Hz 8A	480 / 218

- MATCHING CASH COUNTER AVAILABLE
- OTHER LENGTHS AVAILABLE ON REQUEST
- CORNER UNIT AVAILABLE FOR MULTIPLEXING

*All equipment designed to operate in controlled environment below 75°F (+24°C) temperature and HR 55% relative humidity.

** All measurements are approximates

*** Specifications are subject to change without notice

Web: www.igloorefrigeration.com