

IGLOO Refrigeration Ltd

59 ALNESS STREET UNIT 3 TORONTO ONTARIO CANADA M3J 2H2
 TEL: 416.663.3051 TOLL FREE: 1.888.408.8819 FAX: 416.663.5793

REFRIGERATED SELF SERVED MULTI PURPOSE DISPLAY CASE
MEAT, CHEESE, FISH, DELI AND SUSHI

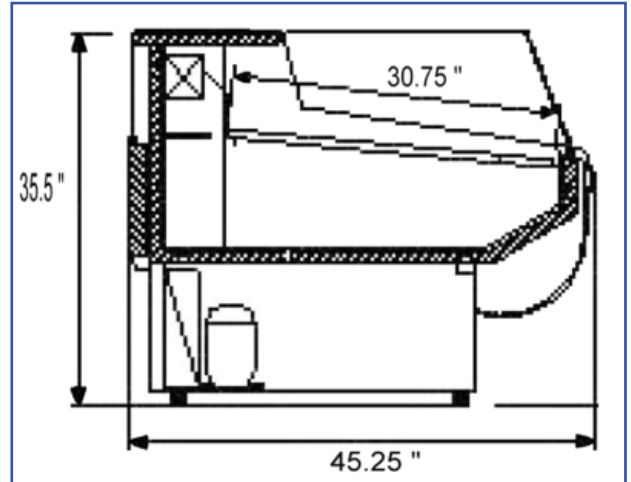

STANDARD:

- Self served low profile open merchandiser
- Granite work counter
- Additional refrigerated under-shelf storage cabinet
- ABS sides - (off-white)
- Painted white front and base
- Front bumper (grey)
- Digital temperature display
- Gravity cooling system
- Automatic defrost cycle
- Automatic condensation disposal
- Front glass defogging system
- Environment friendly R134a or R404A

OPTIONAL:

- Remote compressor
- Corner units available
- All stainless steel base and front
- Custom colours of front bumper
- Possibility of multiplexing
- Custom colours available
- Interior lighting
- Sneeze guard (straight glass or curved glass)

| MODEL | LENGTH | DEPTH | HEIGHT | VOLTAGE | WEIGHT |
|-------------|-----------|----------|---------|--------------|-----------|
| | In./cm | In./cm | In./cm | | Lbs/Kg |
| BLM3 | 41 / 104 | 45 / 115 | 35 / 89 | 115V 60Hz 6A | 290 / 132 |
| BLM4 | 54 / 137 | 45 / 115 | 35 / 89 | 115V 60Hz 7A | 350 / 159 |
| BLM5 | 66 / 168 | 45 / 115 | 35 / 89 | 115V 60Hz 8A | 400 / 181 |
| BLM6 | 79 / 201 | 45 / 115 | 35 / 89 | 115V 60Hz 8A | 450 / 204 |
| BLM8 | 100 / 254 | 45 / 115 | 35 / 89 | 115V 60Hz 8A | 480 / 218 |

- MATCHING CASH COUNTER AVAILABLE
- OTHER LENGTHS AVAILABLE ON REQUEST
- CORNER UNIT AVAILABLE FOR MULTIPLEXING

* All equipment designed to operate in controlled environment below 75°F (+24°C) temperature and HR 55% relative humidity.

** All measurements are approximates

*** Specifications are subject to change without notice

Web: www.igloorefrigeration.com