

IGLOO Refrigeration Ltd

370 NORFINCH DRIVE TORONTO ONTARIO CANADA M3N 1Y4
 TEL: 416.663.3051 TOLL FREE: 1.888.408.8819 FAX: 416.663.5793

HOT FOOD SHOW CASE – “DELUXE” – CURVED FRONT GLASS

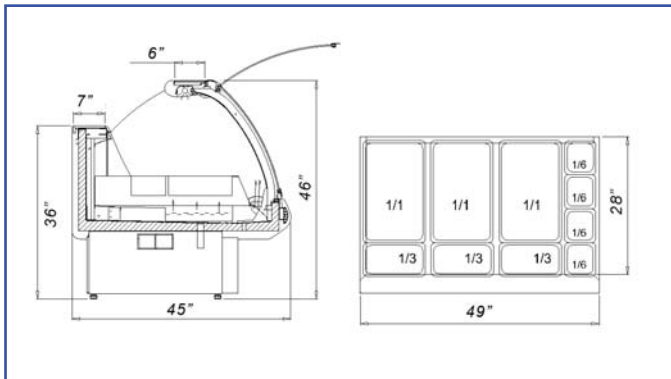

STANDARD:

- Curved glass front glass
- Granite granite work counter
- Body white finish
- Illuminated display area
- Thermostat heat control

NOTE: Panes not included in price

MODEL	LENGTH	DEPTH	HEIGHT	VOLTAGE	WEIGHT
	In./cm	In./cm	In./cm		Lbs/Kg
HFTD3	41 / 104	47 / 119	48 / 123	208 / 115V 60Hz 12A	265 / 120
HFTD5	66 / 167	47 / 119	48 / 123	208 / 115V 60Hz 15A	375 / 170
HFTD6	79 / 200	47 / 119	48 / 123	208 / 115V 60Hz 20A	430 / 195
HFTD8	100 / 254	47 / 119	48 / 123	208 / 115V 60Hz 25A	465 / 210

* All equipment designed to operate in controlled environment below 75°F (+24°C) temperature and HR 55% relative humidity.

** All measurements are approximates

*** Specifications are subject to change without notice

Web: www.igloorefrigeration.com