

IGLOO Refrigeration Ltd

370 NORFINCH DRIVE TORONTO ONTARIO CANADA M3N 1Y4
 TEL: 416.663.3051 TOLL FREE: 1.888.408.8819 FAX: 416.663.5793

HOT FOOD TABLES – CURVED FRONT GLASS



STANDARD:

- Curved glass front glass
- Stainless-steel work counter
- Body white finish
- Illuminated display area
- Low water level alarm system
- Thermostat heat control
- Additional insulated bottom storage

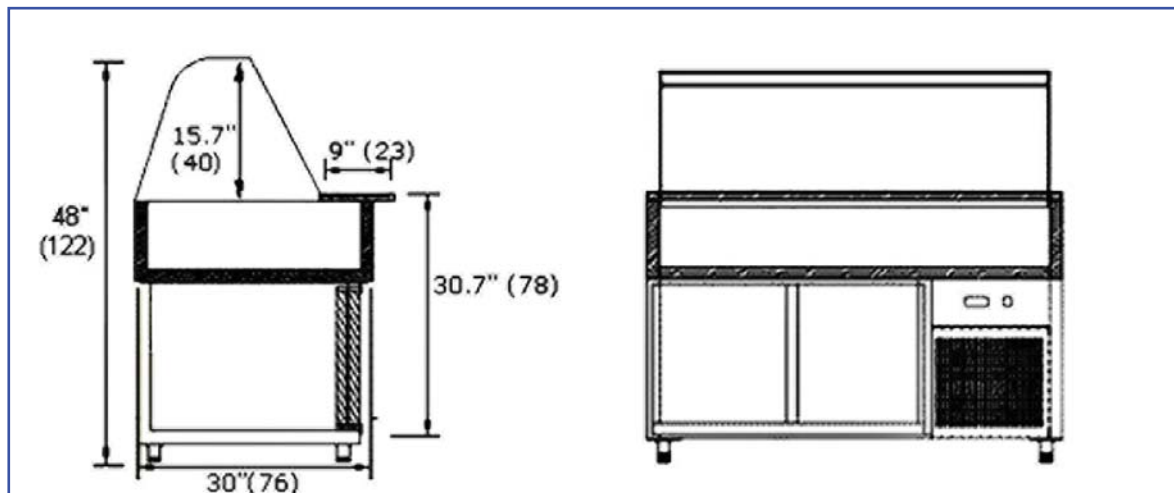

MODEL	LENGTH	DEPTH	HEIGHT	VOLTAGE	WEIGHT
	In./cm	In./cm	In./cm		Lbs/Kg
HFT51	51 / 130	31 / 79	48 / 122	220 V / 115V 60 Hz 13A	330 / 150
HFT59	59 / 150	31 / 79	48 / 122	220 V / 115V 60 Hz 13A	350 / 159

* All equipment designed to operate in controlled environment below 75°F (+24°C) temperature and HR 55% relative humidity.

** All measurements are approximates

*** Specifications are subject to change without notice

Web: www.igloorefrigeration.com