

IGLOO Refrigeration Ltd

59 ALNESS STREET UNIT 3 TORONTO ONTARIO CANADA M3J 2H2
 TEL: 416.663.3051 TOLL FREE: 1.888.408.8819 FAX: 416.663.5793

SALAD BAR – REFRIGERATED, CURVED FRONT GLASS



STANDARD:

- Curved European style front glass
- Stainless-steel work counter
- Body white finish
- Lighted display area
- Automatic defrost cycle
- Digital temperature display
- Automatic condensation disposal
- Environment friendly R134a or R404A
- Additional refrigerated bottom storage

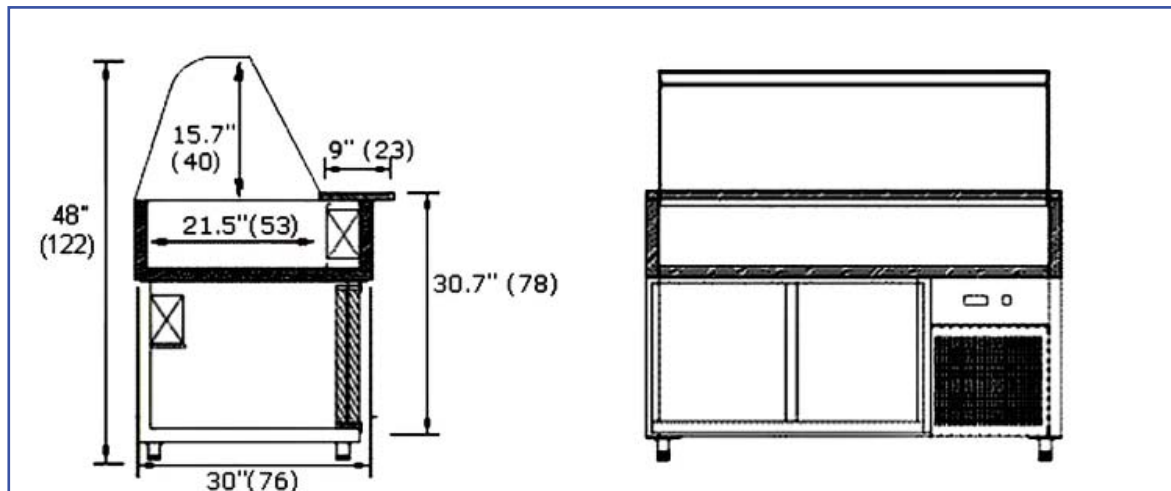

MODEL	LENGTH	DEPTH	HEIGHT	VOLTAGE	WEIGHT
	In./cm	In./cm	In./cm		Lbs/Kg
ESC1	51 / 130	31 / 79	48 / 122	115V 60Hz 7A	330 / 150
ESC2	59 / 150	31 / 79	48 / 122	115V 60Hz 7A	350 / 159
ESC3	67 / 170	31 / 79	48 / 122	115V 60Hz 7A	370 / 168

* All equipment designed to operate in controlled environment below 75°F (+24°C) temperature and HR 55% relative humidity.

** All measurements are approximate

*** Specifications are subject to change without notice

Web: www.igloorefrigeration.com