

# IGLOO Refrigeration Ltd

370 NORFINCH DRIVE TORONTO ONTARIO CANADA M3N 1Y4  
 TEL: 416.663.3051 TOLL FREE: 1.888.408.8819 FAX: 416.663.5793

## GELATO ICE-CREAM FREEZER - WOOD FINISH

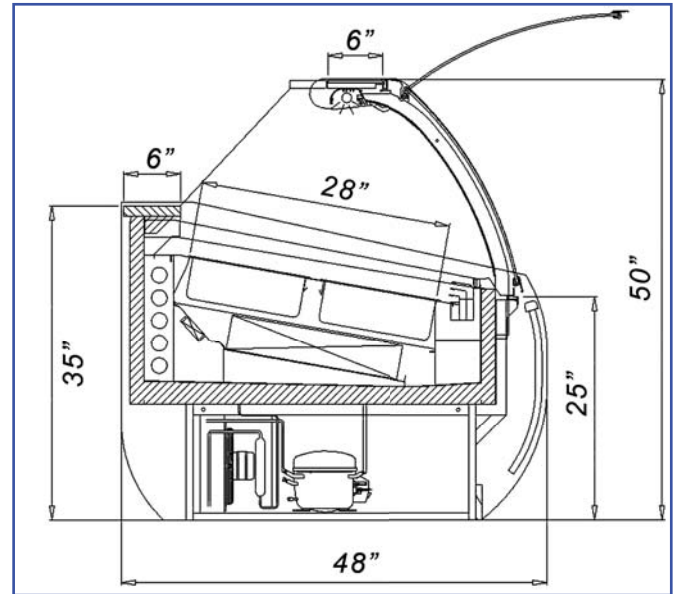

### STANDARD:

- Curved glass front glass
- Wood finish base (cherry)
- Automatic defrost cycle
- Front window defogger
- Interior lighting
- Forced air cooling system
- Stainless-steel counter
- Stainless-steel containers (14 or 28) included
- Environment friendly R404A or R507

### OPTIONAL:

- Remote compressor
- Gold finish trimming

MODEL	LENGTH	DEPTH	HEIGHT	VOLTAGE	WEIGHT
	In./cm	In./cm	In./cm		Lbs/Kg
ARB 4	55.5 / 138.5	48 / 122	50 / 126	115V / 220V (1Phase) 60 Hz 9A	662 / 300
ARB 8	104 / 263	48 / 122	50 / 126	115V / 220V (1Phase) 60 Hz 18A	1146 / 520

\* All equipment designed to operate in controlled environment below 75°F (+24°C) temperature and HR 55% relative humidity.

\*\* All measurements are approximates

\*\*\* Specifications are subject to change without notice

Web: [www.igloorefrigeration.com](http://www.igloorefrigeration.com)