

IGLOO Refrigeration Ltd

59 ALNESS STREET UNIT 3 TORONTO ONTARIO CANADA M3J 2H2
 TEL: 416.663.3051 TOLL FREE: 1.888.408.8819 FAX: 416.663.5793

REFRIGERATED DISPLAY – COUNTER TOP MULTI-USE CASE SALADS, SANDWICHES, SUSHI, AND MORE



STANDARD:

- Curved European style front glass
- All stainless-steel construction
- Stainless-steel pans
- Interior lighting
- Automatic defrost cycle
- Electronic programmable temperature
- Digital temperature display
- Gravity cooling system
- Automatic condensation disposal
- Environment friendly R134a

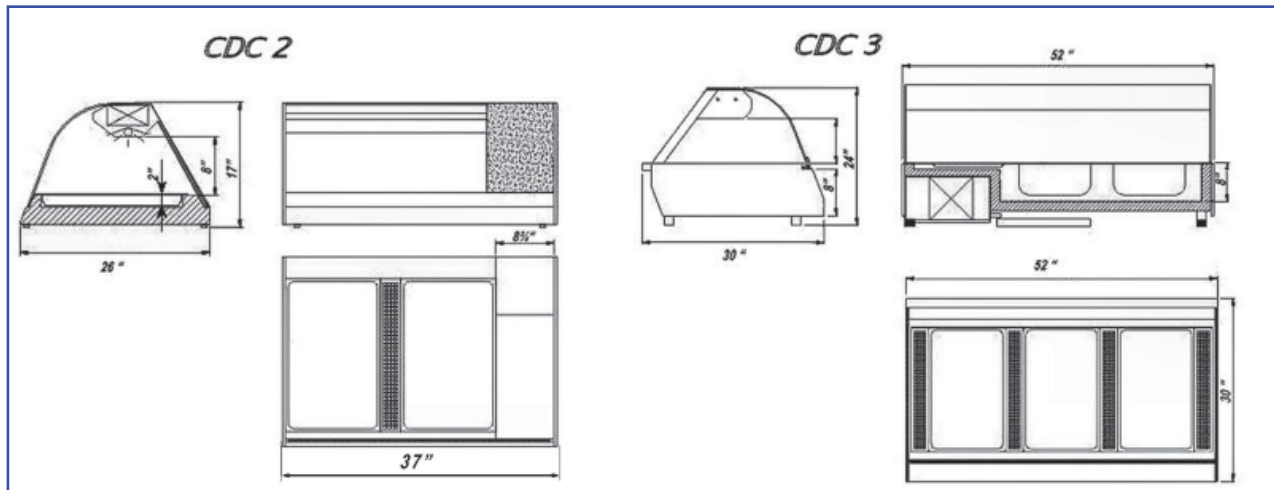

| MODEL | LENGTH | DEPTH | HEIGHT | VOLTAGE | WEIGHT |
|-------|----------|---------|---------|---------------|---------|
| | In./cm | In./cm | In./cm | | Lbs/Kg |
| CDC 2 | 37 / 94 | 26 / 66 | 17 / 43 | 115V 60Hz 10A | 66 / 30 |
| CDC 3 | 52 / 132 | 30 / 77 | 24 / 60 | 115V 60Hz 12A | 99 / 45 |

* All equipment designed to operate in controlled environment below 75°F (+24°C) temperature and HR 55% relative humidity.

** All measurements are approximate

*** Specifications are subject to change without notice

Web: www.igloorefrigeration.com